

RATED POWER

4.5kW@3600rpm



Photographs may show non-standard equipment.

FEATURES and BENEFITS

Emissions

- The Kubota OC60 engine complies with EPA Tier 4 emissions regulations. These are the most stringent emissions regulations in the world in this class.

Durable Power

- This engine offers a seamless transition from Tier 2 to Tier 4 by totally maintaining the same performance and physical characteristics of the previous Tier 2 engines.

Clean and Quiet Power

- The Kubota OC series is an unique engine that has light-weight and compact features of an air-cooled engine together with the low noise, durability and clean exhaust emission of a water-cooled diesel engine. With ACTV (Advanced Cooling Three Vortex) system, the cylinder block is air-cooled, whereas the combustion area of the cylinder head is oil-cooled.

GENERAL SPECIFICATION

Net Intermittent SAE-J1349

Model		OC60-E3
Emission Regulation		Tier 4
Type		4-cycle Oil-air cooled Diesel
Number of Cylinders		1
Bore	mm (in)	72 (2.83)
Stroke	mm (in)	68 (2.68)
Displacement	L (cu.in)	0.276 (16.84)
Combustion System		IDI (TVCS)
Aspiration		Naturally Aspirated
Maximum Speed	rpm	3600
Output: Net Intermittent	kW	4.5
	HP	6.0
	PS	6.1
Oil Pan Capacity	L (gal)	1.3 (0.34)
Starter Capacity	V-kW	12-0.7
Alternator Capacity	V-A	12-4.0
Length	mm (in)	461 (18.15)
Width	mm (in)	403 (15.87)
Height (1)	mm (in)	458 (18.03)
Dry Weight	kg (lb)	38 (84)

*Specification is subject to change without notice.

*Output: Net Intermittent SAE-J1349

*Dry weight is according to Kubota's standard specification. When specification varies, the weight will vary accordingly.

PERFORMANCE CURVE

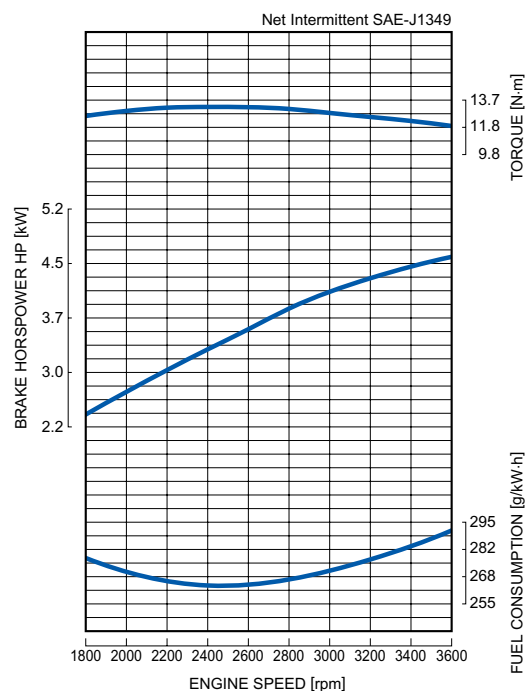

DIMENSIONS

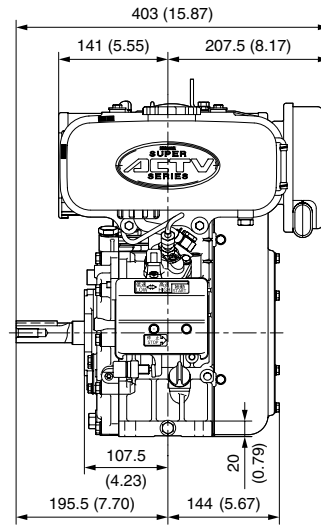
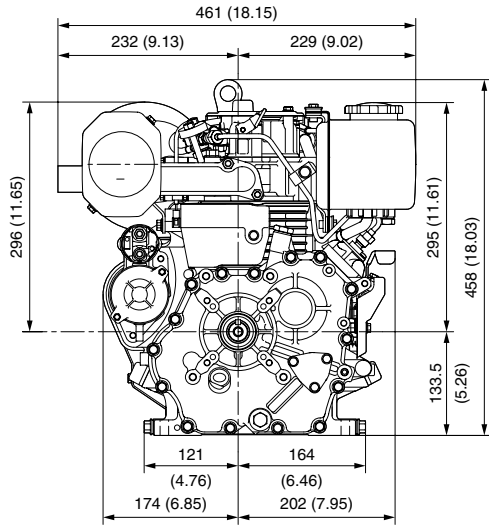

■ Suppliable P.T.O.shafts. Unit:mm(inch)

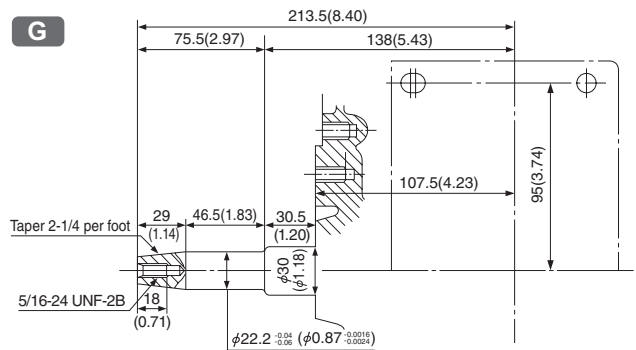
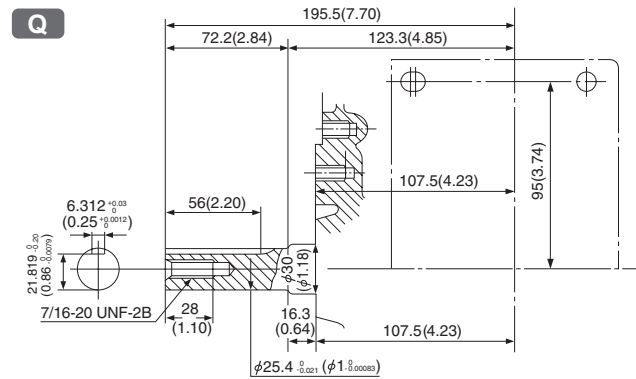
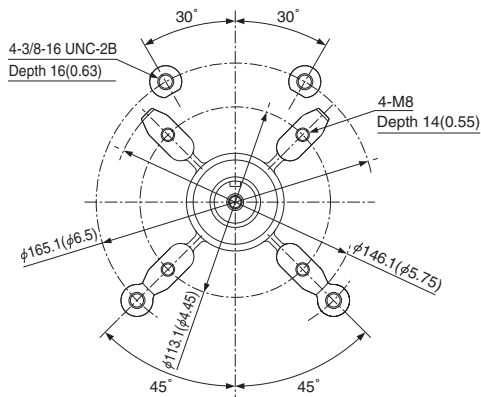

KUBOTA Corporation

2-47, Shikitsuhigashi 1-chome, Naniwa-ku, Osaka, 556-8601 Japan
Fax: 06-6648-3521

<http://engine.kubota.co.jp>

Your Driving Force
KUBOTA ENGINE